

OpenEye[®]

The Cloud Video Platform

4MP MINI IP BULLET CAMERA

HARDWARE MANUAL

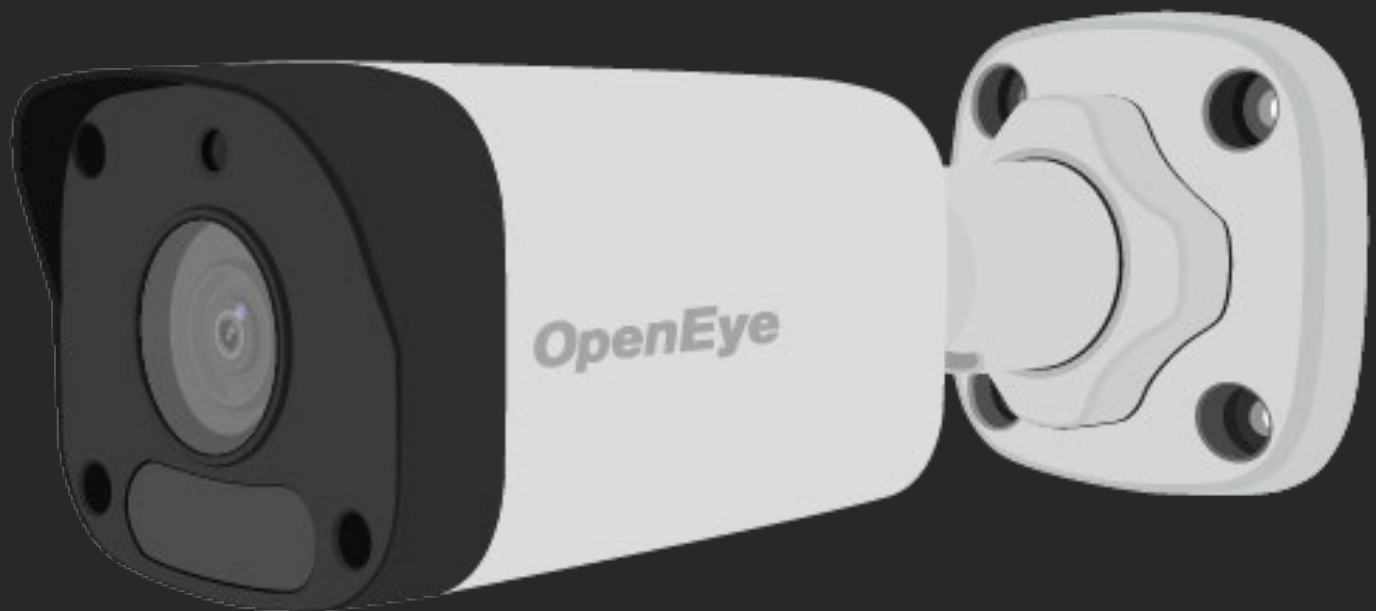

OE-C7044-WR Mini IP Bullet Camera
User Manual

Manual Edition 35358AD – FEBRUARY 2021

©2021, OPENEYE
All Rights Reserved.

No part of this documentation may be reproduced in any means, electronic or mechanical, for any purpose, except as expressed in the Software License Agreement. OpenEye shall not be liable for technical or editorial errors or omissions contained herein. The information in this document is subject to change without notice.

The information in this publication is provided “as is” without warranty of any kind. The entire risk arising out of the use of this information remains with recipient. In no event shall OPENEYE be liable for any direct, consequential, incidental, special, punitive, or other damages whatsoever (including without limitation, damages for loss of business profits, business interruption or loss of business information), even if OPENEYE has been advised of the possibility of such damages and whether in an action or contract or tort, including negligence.

This documentation is copyrighted. All other rights are reserved to OPENEYE. OPENEYE, and OpenEye, are registered trademarks of OPENEYE in the United States and elsewhere; Windows, and Windows XP Embedded are registered trademarks of Microsoft Corporation. All other brand and product names are trademarks or registered trademarks of the respective owners.

OPENEYE
Liberty Lake, WA • U.S.A.

Important Safeguards

1. **Read Instructions**
Read all of the safety and operating instructions before using the product.
2. **Retain Instructions**
Save these instructions for future reference.
3. **Attachments / Accessories**
Do not use attachments or accessories unless recommended by the appliance manufacturer as they may cause hazards, damage product and void warranty.
4. **Installation**
Do not place or mount this product in or on an unstable or improperly supported location. Improperly installed product may fall, causing serious injury to a child or adult, and damage to the product. Use only with a mounting device recommended by the manufacturer, or sold with the product. To insure proper mounting, follow the manufacturer's instructions and use only mounting accessories recommended by manufacturer.
5. **Power source**
This product should be operated only from the type of power source indicated on the marking label.

Precautions

Operating

- Before using, make sure power supply and others are properly connected.
- While operating, if any abnormal condition or malfunction is observed, stop using the camera immediately and then contact your local dealer.

Handling

- Do not disassemble or tamper with parts inside the camera.
- Do not drop or subject the camera to shock and vibration as this can damage camera.
- Care must be taken when you clean the clear dome cover. Scratches and dust will ruin the image quality of your camera. Do not use strong or abrasive detergents when cleaning the camera body. Use a dry cloth to clean the camera when it is dirty. In case the dirt is hard to remove, use a mild detergent and wipe the camera gently.

Installation and Storage

- Do not install the camera in areas of extreme temperatures in excess of the allowable range; install the camera in areas with temperatures within the camera's operating temperature, including the following: -31 ~ 140 °F (-35 ~ 60 °C).
- Avoid installing in humid or dusty places. The relative humidity must be below 90%.
- Avoid installing in places where radiation is present.
- Avoid installing in places where there are strong magnetic fields and electric signals.
- Avoid installing in places where the camera would be subject to strong vibrations.
- Never face the camera toward the sun. Do not aim at bright objects. Whether the camera is in use or not, never aim it at the sun or other extremely bright objects. Otherwise the camera may be smeared and damaged.

Regulation

This device complies with Part 15 of the FCC Rules. Operation is subject to the following two conditions: (1) this device may not cause harmful interference, and (2) this device must accept any interference received, including interference that may cause undesired operation.

Compliance is evidenced by written declaration from our suppliers, assuring that any potential trace contamination levels of restricted substances are below the maximum level set by EU Directive 2002/95/EC, or are exempted due to their application.

Warning

DANGEROUS HIGH VOLTAGES ARE PRESENT INSIDE THE ENCLOSURE.
DO NOT OPEN THE CABINET.
REFER SERVICING TO QUALIFIED PERSONNEL ONLY.

Caution

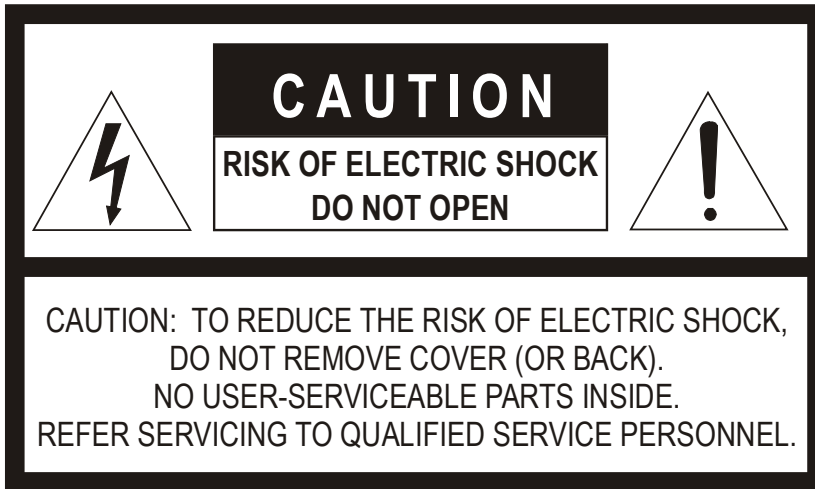

TABLE OF CONTENTS

| | |
|---------------------------------------|-----------|
| Table of Contents | 6 |
| Introduction | 7 |
| Overview | 7 |
| Product Features | 7 |
| Getting Started | 8 |
| Box Contents | 8 |
| Camera Overview | 9 |
| Camera Dimensions | 9 |
| Connections | 10 |
| NETWORK CAMERA MANAGER..... | 11 |
| Launching Network Camera Manager..... | 11 |
| Finding Network Devices..... | 11 |
| Username and Password | 12 |
| Viewing a Network Camera | 12 |
| Live View | 13 |
| Setup & Configuration..... | 14 |
| Basic Camera Settings | 14 |
| Network Settings | 15 |
| IP Address (DHCP/Static IP) | 15 |
| IPv6 Address Configuration | 15 |
| Port-Mapping..... | 16 |
| Streaming Settings | 20 |
| Picture Settings | 24 |
| Scenes | 24 |
| Image Enhancement..... | 25 |
| Exposure | 26 |
| Smart Illumination | 27 |
| White Balance | 27 |
| Advanced | 27 |
| Events Settings..... | 30 |
| Motion Detection | 30 |
| Security Settings..... | 33 |
| Add User | 33 |
| Edit User | 33 |
| Delete User | 33 |
| Maintenance | 37 |
| Software Upgrade | 38 |
| Device Restart..... | 38 |
| Configuration Management..... | 38 |
| Diagnosis Information | 38 |
| Logout..... | 39 |

INTRODUCTION

OVERVIEW

The OE-C7044-WR is a high powered, outdoor IP mini bullet camera equipped with a 4MP 3.6mm lens that provides crisp and clear images. This camera includes WDR and True Day/Night for improved low light performance, and adaptive IR technology to prevent overexposure of objects close to the camera. Network throughput and storage requirements are reduced thanks to H.264 smart encoding technology which dynamically compresses the camera's video to reduce its bitrate. This camera is IP66 rated and functions down to -31°F making it a perfect fit for extreme weather installations. In addition, this camera can be fully powered over PoE, reducing labor costs by eliminating additional cabling requirements and its small form factor gives you peace of mind in any installation location.

All OpenEye IP cameras are fully ONVIF™ compliant and are compatible with the OpenEye Web Services platform, allowing advanced operation, configuration and viewing of high definition video remotely from any Web browser.

PRODUCT FEATURES

- 4MP maximum resolution
- IP66 outdoor rating
- True Day / Night
- True Wide Dynamic Range
- H.264 with Smart Encoding / MJPEG video compression
- 1/3" Progressive CMOS image sensor
- ONVIF™ Profile S compliant

GETTING STARTED

BOX CONTENTS

Before proceeding, please check that the box contains the items listed here. If any item is missing or has defects, DO NOT install or operate the product and contact your dealer for assistance.

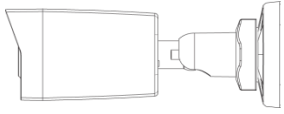
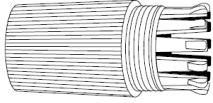
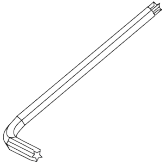
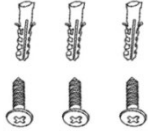
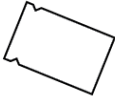
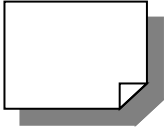
| | |
|--|--|
|  <p>OE-C7044-WR Mini IP Dome Camera</p> |  <p>Waterproof Cable Connector</p> |
|  <p>Torx Tool</p> |  <p>Screws and Plastic Anchors x 3</p> |
|  <p>Desiccant Packet</p> |  <p>Quick Start Guide</p> |

CAMERA OVERVIEW

Before installing or connecting the dome camera, please refer to this section and complete preparations for dome setup and all switch settings.

CAMERA DIMENSIONS

Side

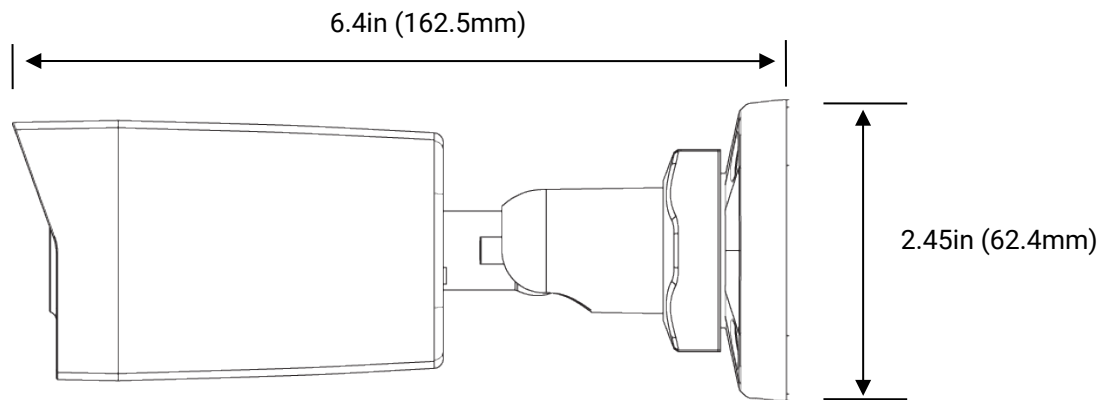

Front

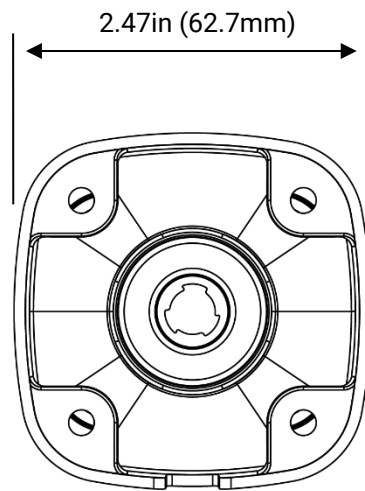

CONNECTIONS

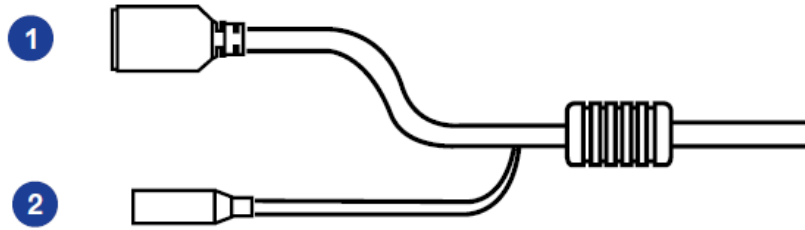

| Pin | Connection | Definition |
|-----|---------------|---------------------------------|
| 1 | RJ-45 | For network and PoE connections |
| 2 | Power (12vDC) | Power connection |

NETWORK CAMERA MANAGER

OpenEye Network Camera Manager (NCM) is a software tool that allows you to quickly and easily connect and configure your OpenEye IP Cameras. This software allows you to apply the camera password, assign IP addresses, configure video settings, and update firmware on multiple cameras at once.

NCM is pre-installed on all OpenEye Recorders and is also available for download www.OpenEye.net for installation on your personal computer or laptop. Network Camera Manager is a Java application, this allows it to be installed on Windows and Linux operating systems.

LAUNCHING NETWORK CAMERA MANAGER

Apex Windows Platforms

Network Camera Manager can be found on the desktop.

Linux Platforms

In the Apex Settings menu, go to the **Cameras** page and click **Advanced**.

FINDING NETWORK DEVICES

Click **Refresh** to reload the Device List.

To narrow your search by **Camera Model** or **Network**, use the **Model Filter** and **Networks** dropdowns.

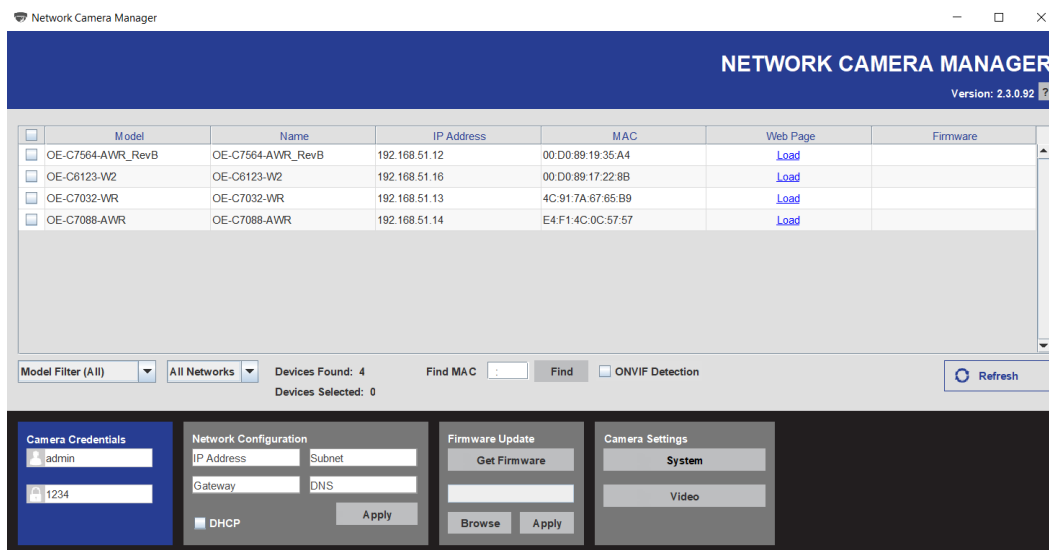

A Mac Address search is also available if you are looking for a specific device.

USERNAME AND PASSWORD

**OpenEye IP cameras ship without a default password.*

Username: **admin**

Note Passwords must be 9-32 characters including at least two elements of the following three: digits, letters, and special characters.

The **admin** user password can be set using the following methods:

1. OpenEye recorders running Apex 2.1 or newer will automatically set a new unique password if:
 - Connected to an M-Series recorder with a built in PoE switch.
 - Connected to a network switch through the camera network port and selected then added in setup, if a new password has not already been set.
2. Connect to the camera directly through a Web Browser and follow the onscreen prompts.
3. Use the Network Camera Manager (NCM) Utility.



Note The NCM Software Manual can be found at <https://www.openeye.net/ncm-manual>.



Note Refer to your Apex recorder manual or quick start guide for instruction on adding cameras.

VIEWING A NETWORK CAMERA

Click **Load** in the row of the desired camera.

Enter a new Admin password.

- Passwords must be a minimum of 9 characters
- Accepted characters: A-Z, a-z, 0-9, all special characters are allowed.

Change Password

Username:

Password:

9 to 32 characters including at least two elements of the following three: digits, letters, and special characters

Weak Medium Strong

Confirm:

OK

LIVE VIEW

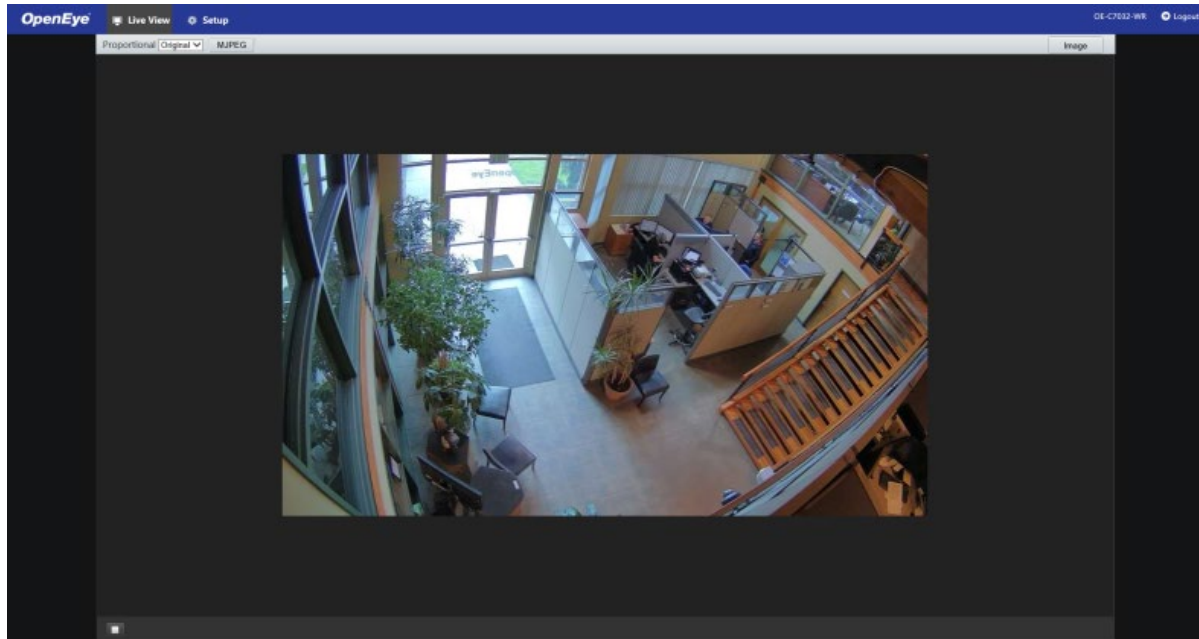

Note Live view is broadcast in MJPEG pass-through. Stream settings will be broadcast to your recording device according to the selected Codec type.

Setup – View additional camera settings.

Proportional – Dropdown menu with Live View image options including:

Stretch: Fit the camera image to the entire viewing window without scaling the image proportionately to the original view.

Scale: Fit the camera image to the entire viewing window, including scaling the image proportionately to the original view.

Original: The camera image will fit in the viewing window in accordance with the default image resolution.

Image – Shortcut to camera Image Setup menu.

Logout – Log out of the currently displayed camera.

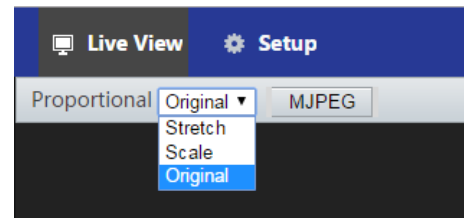

SETUP & CONFIGURATION

BASIC CAMERA SETTINGS

Basic Information

The Basic Information tab displays the product model, firmware, network, and MAC address for the connected camera, along with the current camera Status.

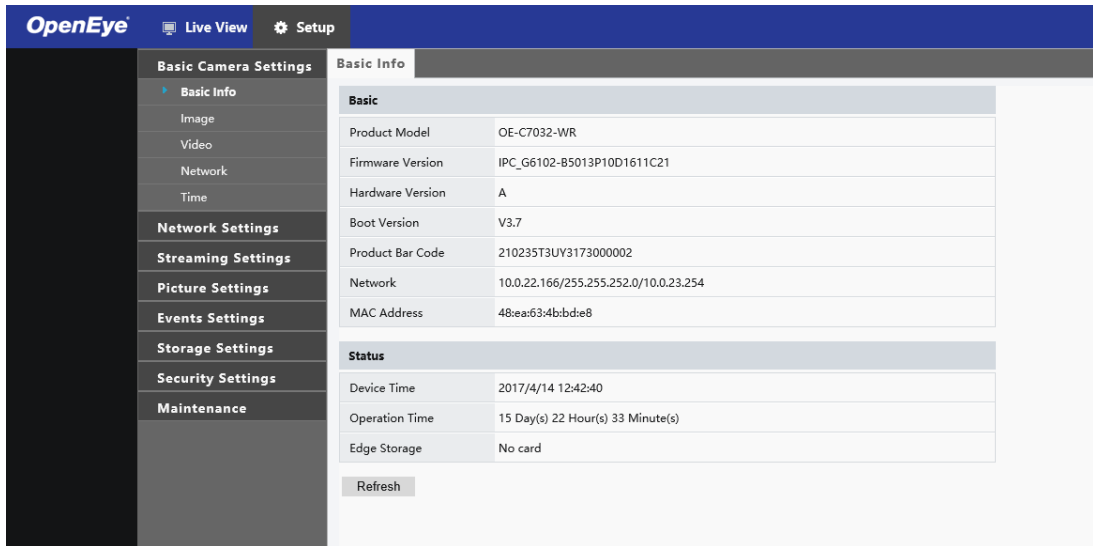

The screenshot shows the OpenEye camera settings interface. The top navigation bar includes 'OpenEye', 'Live View', and 'Setup'. The left sidebar lists various settings categories: Basic Camera Settings, Basic Info, Image, Video, Network, Time, Network Settings, Streaming Settings, Picture Settings, Events Settings, Storage Settings, Security Settings, and Maintenance. The 'Basic Info' tab is selected, displaying a table of camera information and a 'Status' section.

| Basic | |
|------------------|---------------------------------------|
| Product Model | OE-C7032-WR |
| Firmware Version | IPC_G6102-B5013P10D1611C21 |
| Hardware Version | A |
| Boot Version | V3.7 |
| Product Bar Code | 210235T3UY3173000002 |
| Network | 10.0.22.166/255.255.252.0/10.0.23.254 |
| MAC Address | 48:ea:63:4b:bd:e8 |

| Status | |
|----------------|-----------------------------------|
| Device Time | 2017/4/14 12:42:40 |
| Operation Time | 15 Day(s) 22 Hour(s) 33 Minute(s) |
| Edge Storage | No card |

Refresh

The nested Image, Video, Network, and Time tabs are shortcuts to the more advanced menu options further down the Setup list. For more information about these tabs, see the appropriate sections later in the manual.

NETWORK SETTINGS

Network

The Network tab allows you to configure the connected camera network settings.

IP Address (DHCP/Static IP)

You can use the dropdown menu to choose to use a Static (fixed) IP address, PPPoE, or a dynamic IP address (assigned by a DHCP server or router) for the camera.

To set up a new static IP address:

1. Select the Static IP dropdown option.
2. Type a new IP address in the **IP address** box.
3. Type a new address in the **Subnet Mask** box.
4. Type a new address in the **Default Gateway** box.
5. Click **Save** to confirm the new setting.

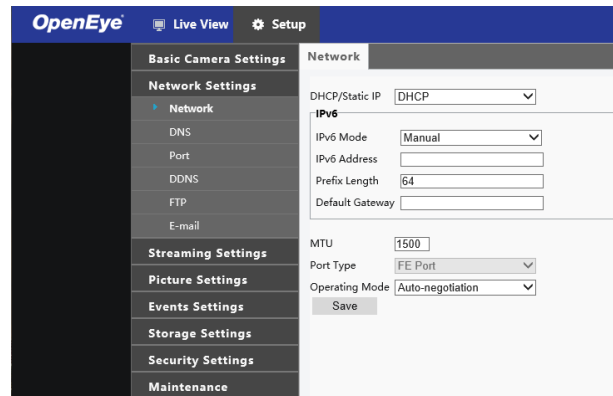

IPv6 Address Configuration

To enable IPv6 select **Enable IPv6** and click **Save**. See your network administrator if you are unsure of your network configuration.

When using static IP address to log in to the IP Camera, you can access it either through OpenEye IP Finder software or type the IP address directly in the address bar of your web browser.

IP Address – The IP Address is necessary for network identification.

Subnet mask – Used to determine if the destination is in the same subnet. The default value is 255.255.255.0.

Default gateway – Used to forward frames to destinations on different subnets or for internet access.

Web Server port – Defines the port that Internet Explorer uses to connect over the web and view video. If this port is changed then the new port must be defined when attempting to web connect (ex: if your camera's IP address is 192.168.0.100 and you change the web port to 8001, then you must type http://192.168.0.100:8001 in your browser).

DNS

Set your preferred DNS and alternate DNS server.

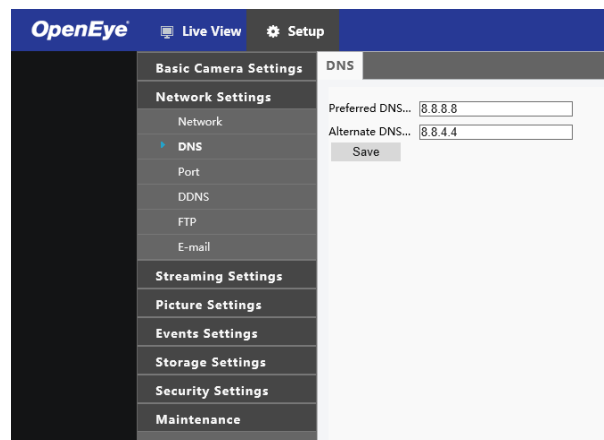

Port

OpenEye Live View Setup

Port

HTTP Port:

HTTPS Port:

RTSP Port:

Note: Modifying the RTSP or server port number will cause the device to restart.

Save

Port Mapping: Enable Disable

Mapping Type:

| Port Type | External Port | External IP | Status |
|-----------|----------------------------------|-------------|----------|
| HTTP | <input type="text" value="80"/> | 0.0.0.0 | Inactive |
| RTSP | <input type="text" value="554"/> | 0.0.0.0 | Inactive |
| Server | <input type="text" value="81"/> | 0.0.0.0 | Inactive |

Save

HTTP Port – Configure your relevant port number.



Note If the HTTP port number has been occupied already, a “Port conflicts” message will display. Ports 23, 81, 82, 85, 3260, and 49152 are occupied by default.

HTTPS Port – The default HTTPS Port is 443; setting range: 1024 ~65535.

RTSP Port – The default RTSP port is 554; setting range: 1024 ~65535.



Note No port number can be used in duplication on more than one item.

Port-Mapping

To enable Port-Mapping:

1. Check the Port-Mapping **Enable** checkbox.
1. Use the **Mapping Type** dropdown menu to select a type.
2. If selecting **Manual**, the external ports must be configured.



Note If the configured port is already occupied, then the Status will show as inactive and a new port must be selected.

3. Click **Save**.

DDNS

DDNS (Dynamic Domain Name Service) is a service that allows a connection to an IP address using a hostname (URL) address instead of a numeric IP address. Most ISPs use Dynamic IP Addressing that frequently changes the public IP address of your internet connection; this means that when connecting to the camera over the internet, you need to know if your IP address has changed. DDNS automatically redirects traffic to your current IP address when using the hostname address.

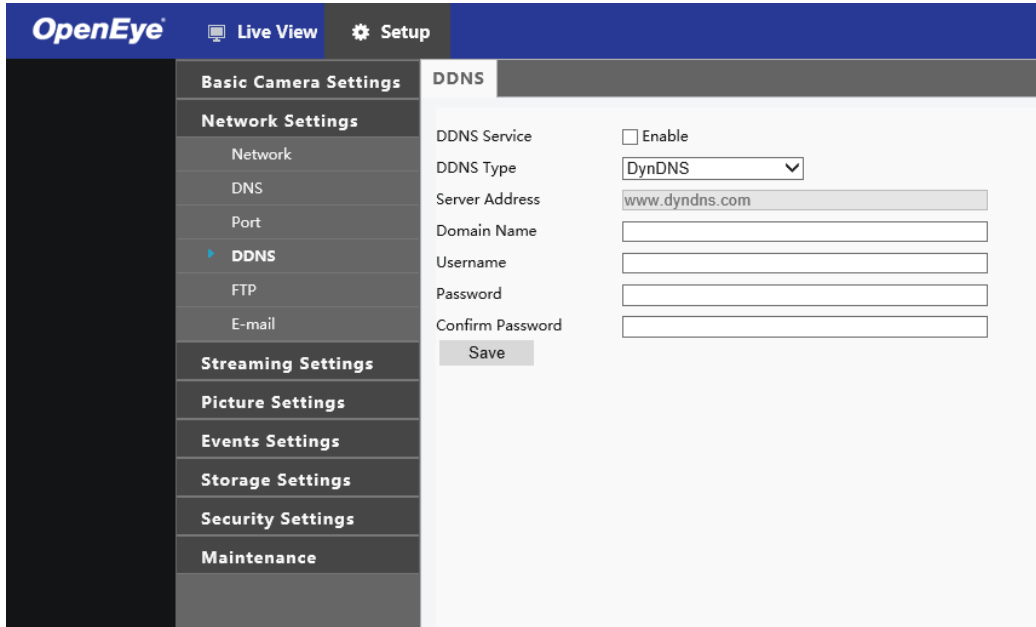

The screenshot shows the OpenEye camera web interface. At the top, there is a navigation bar with 'OpenEye' on the left, 'Live View' in the center, and 'Setup' on the right. Below this is a sidebar menu with categories: 'Basic Camera Settings', 'Network Settings', 'Streaming Settings', 'Picture Settings', 'Events Settings', 'Storage Settings', 'Security Settings', and 'Maintenance'. Under 'Network Settings', 'DDNS' is selected. The main content area is titled 'DDNS' and contains the following fields:

- DDNS Service: Enable
- DDNS Type:
- Server Address:
- Domain Name:
- Username:
- Password:
- Confirm Password:

A 'Save' button is located at the bottom of the form.

Enable DDNS – Select the check box to enable DDNS.

DDNS Type / Server Address – Enter the DDNS type provided by your DDNS server.

Domain Name – Type the registered domain name in the field.

Username/E-mail – Type the username or e-mail required by the DDNS provider for authentication.

FTP

Use FTP (file transfer protocol) to upload snapshots form network cameras to a specified server.

The screenshot shows the OpenEye web interface for configuring FTP. The left sidebar lists various settings categories, with 'FTP' selected. The main content area is titled 'FTP' and contains two sections: 'Server Parameters' and 'Snapshot Image'. The 'Server Parameters' section includes fields for Server IP (192.168.0.150), Port No. (21), Username, Password, Upload Images (checkbox), Overwrite Storage (checkbox), and Overwrite At(image) (1000). The 'Snapshot Image' section includes a 'Save To Root Directory' field with four 'Disable' dropdowns, a 'File Name' field, a 'Separator' dropdown, and a table with 5 rows for naming elements. The table has columns 'No.' and 'Naming Element'. The first row has '1' and 'None'. Below the table is a 'Save' button.

To configure FTP:

1. Enter the **Server IP** address and **Port Number**.
2. Enter the **Username** and **Password** for the upload account.
3. Enable **Upload Images** and/or **Overwrite Storage**, and set the Overwrite Image threshold.
4. Click **Save**.

Email

The camera can send an e-mail via Simple Mail Transfer Protocol (SMTP) when a variety of events occur. SMTP is a protocol for sending e-mail messages between servers. SMTP is a relatively simple, text-based protocol, where one or more recipients of a message are specified and the message text is transferred. The configuration page is shown as follows: Two sets of SMTP accounts can be configured. Each set includes SMTP Server, Account Name, Password and E-mail Address settings. For SMTP server, contact your network service provider for more specific information.

The screenshot displays the OpenEye camera configuration interface. At the top, there is a navigation bar with the OpenEye logo, a 'Live View' button, and a 'Setup' button. A sidebar on the left contains a menu of settings categories: Basic Camera Settings, Network Settings, Streaming Settings, Picture Settings, Events Settings, Storage Settings, Security Settings, and Maintenance. The 'E-mail' option is selected and highlighted. The main content area is titled 'E-mail' and is divided into two sections: 'Sender' and 'Recipient'. The 'Sender' section includes fields for Name, Address, SMTP Server, SMTP Port (set to 25), SSL (with an 'Enable' checkbox), Snapshot Interval(s) (set to 2), and Server Authentication (with an 'Enable' checkbox). There are also checkboxes for 'Attach Image' and fields for Username and Password. The 'Recipient' section includes three sets of fields for Name and Address, labeled Name1, Address1, Name2, Address2, Name3, and Address3. A 'Save' button is located at the bottom of the configuration area.

| Sender | |
|-----------------------|---|
| Name | <input type="text"/> |
| Address | <input type="text"/> |
| SMTP Server | <input type="text"/> |
| SMTP Port | <input type="text" value="25"/> |
| SSL | <input type="checkbox"/> Enable |
| Snapshot Interval(s) | <input type="text" value="2"/> <input checked="" type="checkbox"/> Attach Image |
| Server Authentication | <input checked="" type="checkbox"/> Enable |
| Username | <input type="text"/> |
| Password | <input type="text"/> |

| Recipient | |
|-----------|----------------------|
| Name1 | <input type="text"/> |
| Address1 | <input type="text"/> |
| Name2 | <input type="text"/> |
| Address2 | <input type="text"/> |
| Name3 | <input type="text"/> |
| Address3 | <input type="text"/> |

STREAMING SETTINGS

Video

The Video Settings menu configures the camera's basic settings, including frame rate, bit rate, and the image quality.

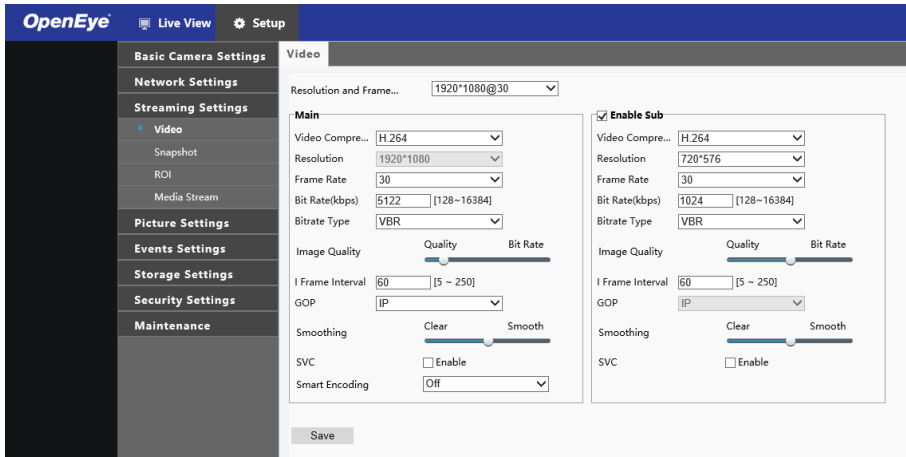

To configure the camera streams:

1. Use the dropdown menus to configure the **Video Compression, Frame Rate Bitrate Type, GOP, and Smart Encoding.**
2. Enable and configure the **Sub-Stream** if desired.
3. Click **Save** to save each selection.

Smart Encoding – Turn on Smart Encoding to enable H.264+ encoding to reduce bit rate.

Resolution and Frame Rate – Use the dropdown menu to select the base resolution and frame rate for the main stream.



Note Higher frame rate will increase video smoothness, but will increase file size and bandwidth usage. Lowering the frame rate will conserve file size and bandwidth usage at the expense of video smoothness.

Video Compression – H.264, H.265, and MJPEG are available for video compression.

Image Quality – If the Encoding Mode is set to VBR, you can adjust the quality level for images by moving the sliding bar. The Quality side of the bar improves video quality, and the Bit Rate side of the bar reduces Bit rate.

I-Frame Interval / GOP – The Group of Pictures setting allows you to modify the frame structure of the video stream. This setting changes the frequency of the I-frames that occur within the stream of P-frames. Increasing this number increases the number of P-frames between each I-frame, decreasing the file size of the stream, but increasing the risk of video decoding errors. It is recommended setting the GOP to be approximately twice the frame rate.

Smoothing – Configure the amount of video smoothing. Moving the sliding bar toward Smoothing increases the level of smoothing but may affect image quality.

Smart Encoding – The camera may be equipped with smart compression (H.264+), which drastically reduces the overall bit rate.



Note In a poor network environment, you can enable smoothing to get more fluent video.

Snapshot

The Snapshot tab is used to configure the settings for timed or continual snapshots.

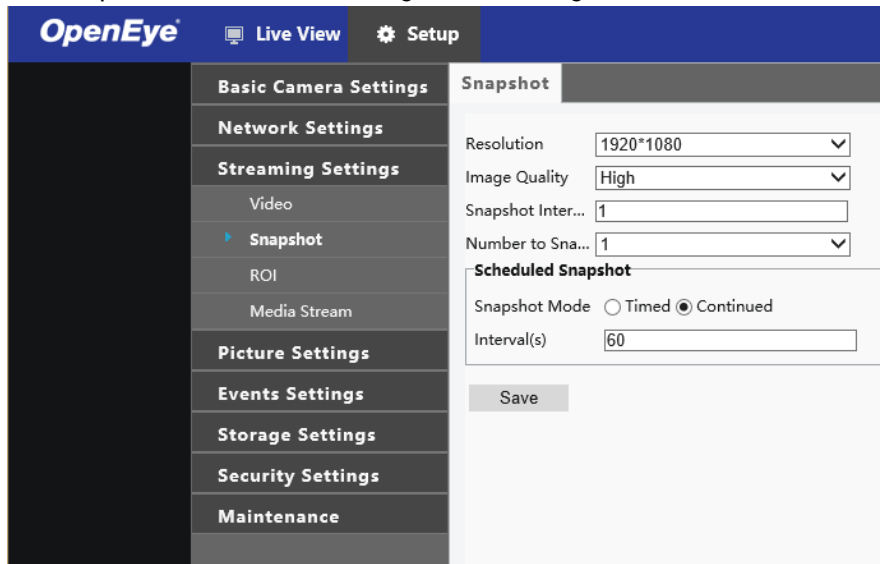

The screenshot shows the OpenEye Setup interface. The top navigation bar includes 'OpenEye', 'Live View', and 'Setup'. The left sidebar lists various settings categories: Basic Camera Settings, Network Settings, Streaming Settings, Video, Snapshot (selected), ROI, Media Stream, Picture Settings, Events Settings, Storage Settings, Security Settings, and Maintenance. The main content area is titled 'Snapshot' and contains the following configuration options:

- Resolution: 1920*1080 (dropdown)
- Image Quality: High (dropdown)
- Snapshot Inter...: 1 (input field)
- Number to Sna...: 1 (dropdown)
- Scheduled Snapshot**
 - Snapshot Mode: Timed Continued
 - Interval(s): 60 (input field)

A 'Save' button is located at the bottom of the configuration area.

To configure Snapshots:

1. Use the dropdowns to select the desired **Resolution, Image Quality, Snapshot Interval,** and the **Number of Snapshots.**
2. If you desire Scheduled Snapshots, select **Timed** Snapshot Mode, and designate an **Interval.**
3. Click **Save.**

Region of Interest (ROI)

When Region of Interest (ROI) is enabled, the system ensures the image quality for the ROI first if the bit rate is insufficient.

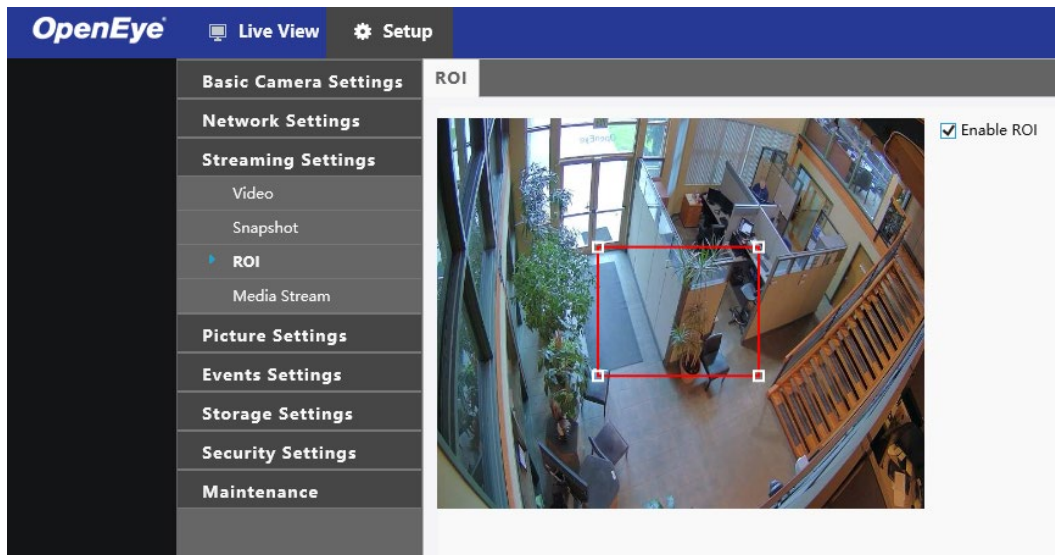

To enable ROI:

1. Check the **Enable ROI** checkbox.
2. Arrange the red ROI square as desired in the camera image. Click and drag to move the square, and use the corner markers to expand the square. The interior of the ROI square will be considered the ROI.

Your changes will be saved automatically.

Media Stream

You can display the established media streams from a camera. You can also set the camera to transmit code streams by the UDP or TCP protocol to a specified IP address and port number.



Note Changes to the media stream will take effect after the camera has been restarted.

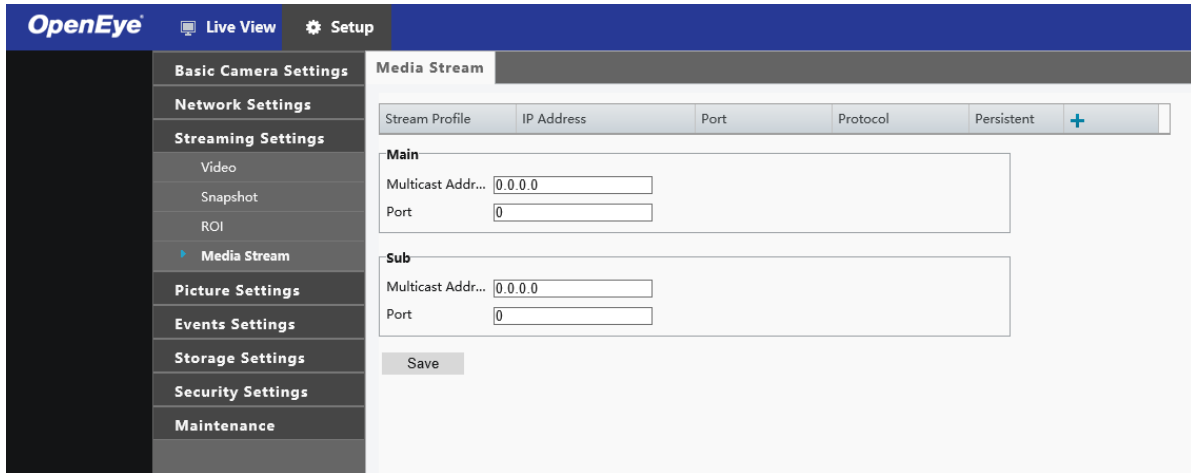

To configure media streams:

1. Click the **+** on the right side of the title bar and the Add Media Stream page will appear.



2. Select a **Stream Type**, and then set the **IP Address** and **Port Number** of the unicast or multicast group for the decoding device that receives audio and video streams from the camera.

| | |
|----------------|---|
| Stream Profile | Main |
| IP Address | |
| Port | |
| Protocol | TS/UDP |
| Persistent | <input type="radio"/> Enable <input checked="" type="radio"/> Disable |

3. Check the **Enable Persistent** checkbox if you want the device to establish the media stream that you have just configured automatically upon each subsequent restart.
4. Click **Save**.
5. Click the **Delete** icon to delete a created media stream.

| Stream Profile | IP Address | Port | Protocol | Persistent | |
|----------------|-------------|------|----------|------------|--|
| Main | 10.0.30.165 | 80 | UDP | Disable | |

PICTURE SETTINGS







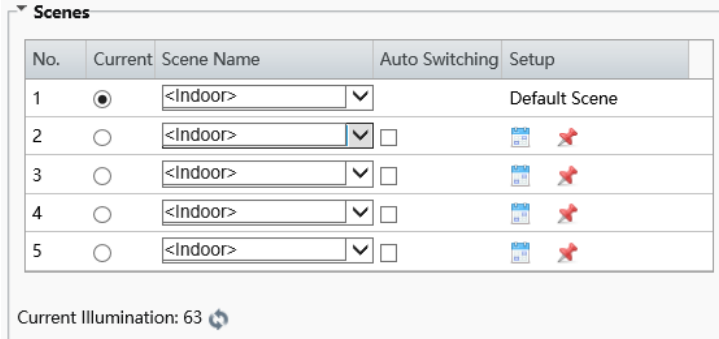

Image

The Image tab allows you to configure the setting for the camera image as seen in Live View. When adjusting your image settings, the changes will be saved automatically and will display in the camera image preview window.

Scenes

Scene allows you to set the image parameters to achieve the desired image effects based on live video in different environments.



| No. | Current | Scene Name | Auto Switching | Setup |
|-----|----------------------------------|------------|--------------------------|---|
| 1 | <input checked="" type="radio"/> | <Indoor> | <input type="checkbox"/> | Default Scene |
| 2 | <input type="radio"/> | <Indoor> | <input type="checkbox"/> |   |
| 3 | <input type="radio"/> | <Indoor> | <input type="checkbox"/> |   |
| 4 | <input type="radio"/> | <Indoor> | <input type="checkbox"/> |   |
| 5 | <input type="radio"/> | <Indoor> | <input type="checkbox"/> |   |

Current Illumination: 63 

To configure Scenes:

1. Click the **Current** checkbox of the desired Scene.



Note Select an option button to switch to the scene and display the corresponding image parameters for the scene. The camera switches the current scene automatically when Enable Auto Switching is selected.

2. Select a **Screen Name** from the dropdown, or select **Custom** and enter one of the common options below.

Common – Recommended for outdoor scenes.

Indoor – Recommended for indoor scenes.

License Plate – Recommended for plate snapshots on roads.

High Sensitivity – Recommended for scenes with low light.

Highlight Supression – Recommended for scenes with intense light.

WDR – Recommend for scenes with high-contrast lighting, such as a window, corridor, front door, or scenes that contain an indoor/outdoor contrast.

Vivid – Increases the saturation of the image based on the standard mode.

Bright – Increases the brightness of the image based on standard mode.

3. Use the **Default Scene Pin** icon to set the desired Scene as default.

If auto-switching is enabled, the camera can switch to the scene automatically when the condition for switching to a non-default scene is met.

Image Enhancement

Use the sliding scales to adjust the Image Settings, or set a numeric value in the value box. The dropdown Image Rotation menu will rotate the camera image.

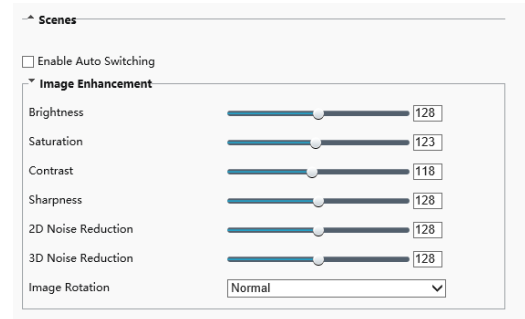

Exposure

By default, the Exposure Mode is set to Automatic. Other options include Custom, Indoor 50hz, Indoor 60hz, and Manual. Using Custom or Manual allows you to manually configure the shutter and gain control.

The screenshot shows the 'Exposure' settings menu with the following options:

- Exposure Mode: Automatic (dropdown)
- Shutter(s): 1/60 (dropdown)
- Gain: 0 (slider)
- Slow Shutter: Off (radio button)
- Slowest Shutter: 1/15 (dropdown)
- Compensation: -15 (slider)
- Metering Control: Center-Weighted Average Metering (dropdown)
- Day/Night Mode: Automatic (radio button)
- Day/Night Sensitivity: Medium (dropdown)
- Day/Night Switching(s): 3 (dropdown)
- WDR: Automatic (dropdown)
- WDR Level: 5 (slider)
- WDR Open Sensitivity: 5 (slider)
- WDR Close Sensitivity: 5 (slider)

Shutter – Control the light that enters into the camera lens. A fast shutter speed is ideal for scenes with fast movement.



Note You can set a shutter speed when Exposure Mode is set to Manual or Custom.

Gain – Controls the amplification of the signal from the camera sensor, allowing the camera to output video signals according to the light conditions.



Note You can set this parameter only when Exposure Mode is set to Manual or Custom.

Slow Shutter – Improve image brightness in low light conditions.

Slowest Shutter – Set the slowest shutter speed that can be used during exposure.

Compensation – Customize the compensation up or down to get the optimal camera image.

Metering Control – Designate the way the camera measures the intensity of light.

Center-Weighted Average Metering: Prioritizes the middle section of the image and is most useful when the subject is in the center of the scene or when the scene is evenly lit.

Evaluate Metering: Allows you to select a portion of the image to apply the metering control to.

Spot Metering: Uses a small point in the center of the scene to meter exposure. This mode is useful in scenes with bright back grounds or a large amount of contrast

Day/Night Mode –

Automatic/Day/Night: Allows you to set the camera to automatically switch between night mode and day mode, set to On, or set to Off.

Day/Night Switching: Set the length of time before the camera switches between day mode and night mode after the conditions for switching are met.

WDR – Set WDR to Automatic, On, or Off and adjust the WDR sensitivity.

WDR Level – Improve the image by adjusting the WDR level. For areas of higher contrast, a WDR level of 7 or higher is recommended.

Smart Illumination

Toggle Smart Illumination **Enabled** or **Off**, and then use the dropdown menus to customize the Lighting Type, Control Mode, and Illumination Level.



Smart Illumination

Smart Illumination Enable Off

Lighting Type

Control Mode

Illumination Level

White Balance

Use the white balance setting to change color representation in difficult lighting conditions.



White Balance

White Balance

Red Offset

Blue Offset

Auto – White balance works within its

color temperature range and calculates the best-fit white balance.

Outdoor, Fine Tune, Sodium Lamp, and Locked – Advanced settings to customize your White Balance based on the scene.



Note It is recommended to use Auto and Auto 2 to cover most use cases.

Advanced

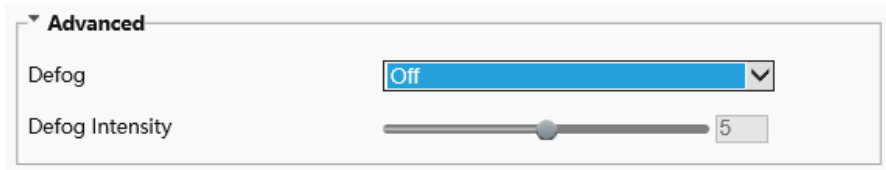

Advanced

Defog

Defog Intensity

Defog – Adjust the clarity of images captured in fog or haze conditions.

1. Use the Defog dropdown menu to turn Defog **On** or **Off**.
2. Slide the **Defog Intensity** bar to the desired position (1 is the minimum intensity and 5 is the maximum intensity).



Note The Defog function is only available when WDR is disabled.

On-Screen Display

Up to 8 on-screen displays (OSD) can be configured for the camera image.

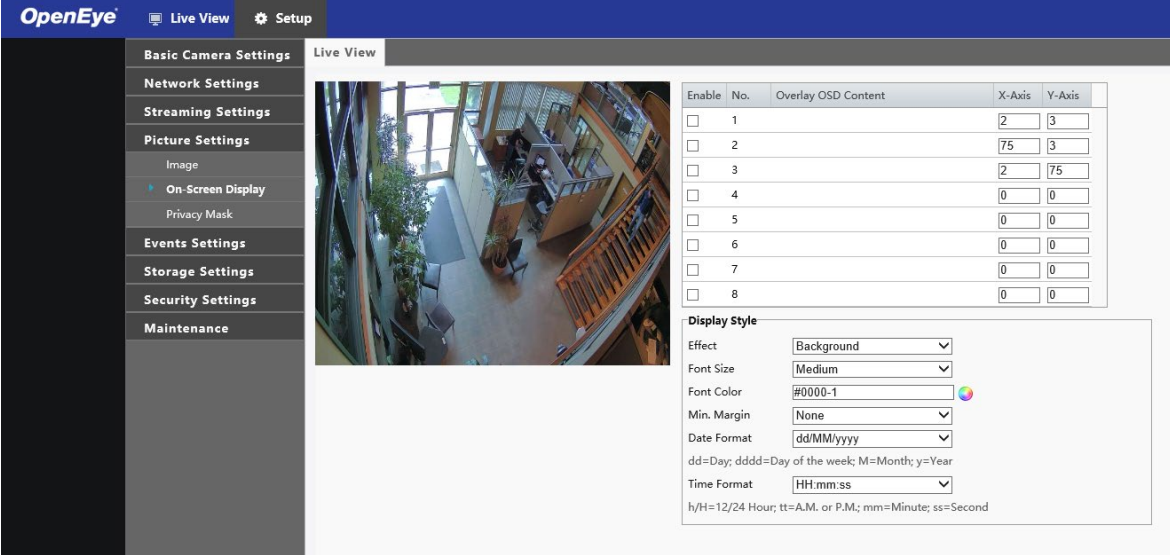

| Enable | No. | Overlay OSD Content | X-Axis | Y-Axis |
|--------------------------|-----|---------------------|--------|--------|
| <input type="checkbox"/> | 1 | | 2 | 3 |
| <input type="checkbox"/> | 2 | | 75 | 3 |
| <input type="checkbox"/> | 3 | | 2 | 75 |
| <input type="checkbox"/> | 4 | | 0 | 0 |
| <input type="checkbox"/> | 5 | | 0 | 0 |
| <input type="checkbox"/> | 6 | | 0 | 0 |
| <input type="checkbox"/> | 7 | | 0 | 0 |
| <input type="checkbox"/> | 8 | | 0 | 0 |

Display Style

Effect: Background

Font Size: Medium

Font Color: #0000-1

Min. Margin: None

Date Format: dd/MM/yyyy

Time Format: HH:mm:ss

h/H=12/24 Hour; tt=A.M. or P.M.; mm=Minute; ss=Second

To add an on-screen display:

1. Check the **Enable** checkbox for the desired OSD.
2. Type the **X** and **Y axis** coordinates to set the OSD location on the camera image, or click and drag the OSD to the desired location.
3. Click in the **Overlay OSD Content** column and use the dropdown menu to select the desired OSD content.
4. If desired, use the **Display Style** options to further configure the OSD.



Note To view the OSD in the web browser Live View, you must refresh the browser after setting the OSD for the changes to take effect.

Privacy Mask

Add a privacy mask to your camera image to hide desired areas from view.

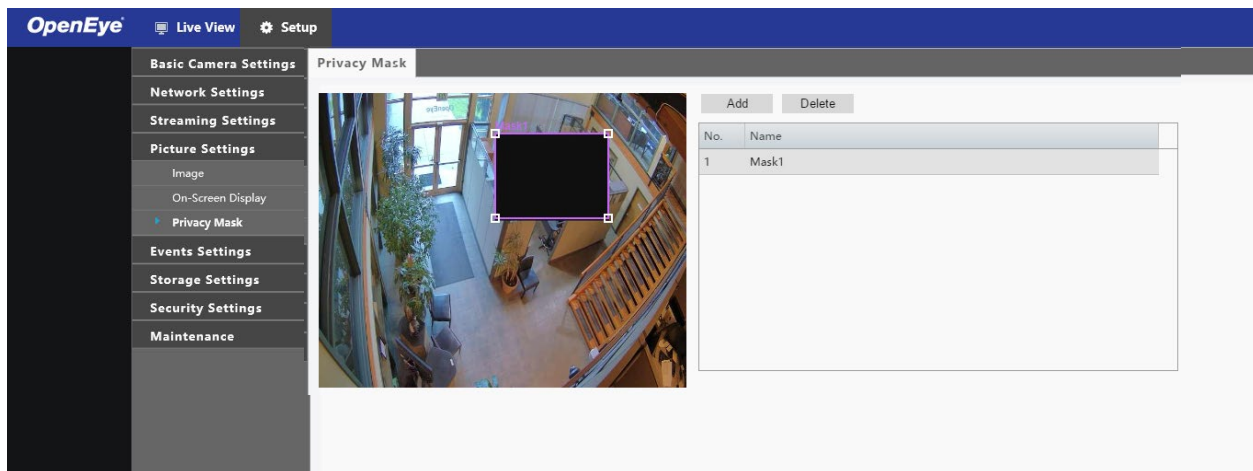

To add a privacy mask:

1. Click **Add**.
2. Click and drag the newly generated **mask square** to the desired location on the camera image. Arrange and resize the mask square as desired.

Your changes will be saved automatically.

To delete a created privacy mask:

1. Select the desired mask from the Privacy Mask list.
2. Click **Delete**.

EVENTS SETTINGS

Alarms

Motion Detection

Motion detection is used to detect motion in a specified area during a period of time. The use of motion detection requires setting a detection area, detection sensitivity, object size, and history. When these requirements are met, the motion detection alarm will activate.

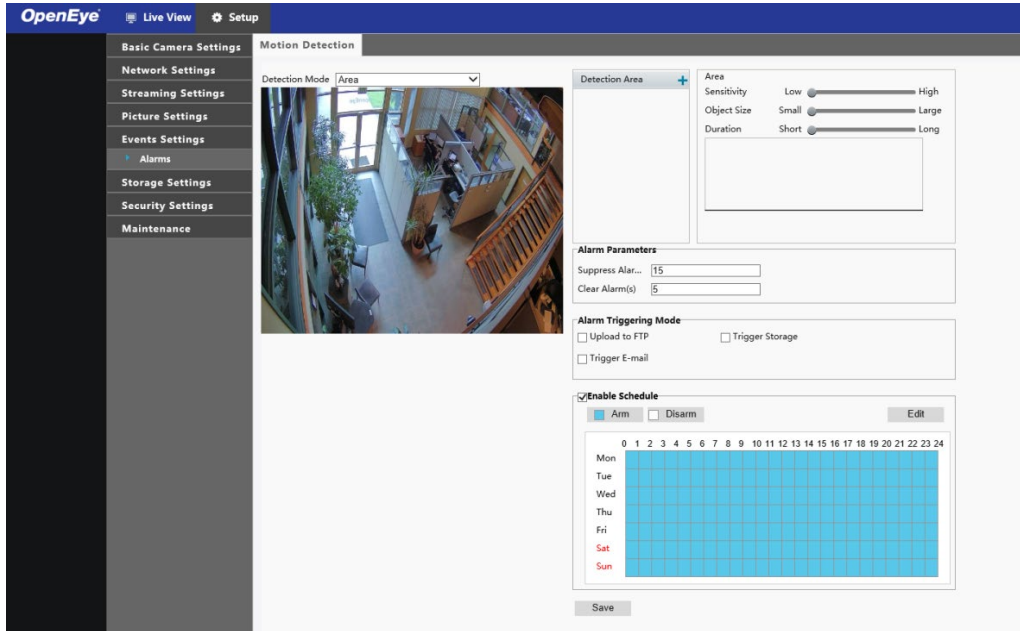

To configure Motion Detection:

1. Click and drag the **detection box** to the desired location on the camera image, and use the corner markers to adjust the size of the detection box as desired.
2. Use the **Sensitivity**, **Object Size**, and **Duration** slider bars to adjust the motion detection parameters as desired.

Sensitivity – This determines how many pixels have to change in order for the alarm to consider motion to have occurred.

Object Size – This determines the area within the camera image that the motion must exceed in order for the alarm to consider motion to have occurred.

Duration – This determines how long the camera image must be changing before alarm considers motion to have occurred.

3. Set the **Alarm Parameters**.

Suppress Alarm – After an alarm is triggered, the same alarm will not be reported again within the designated time.

Clear Alarm – After the alarm is triggered:

- a) If the same alarm is not triggered within the set time, the alarm will be cleared and the same alarm can be reported again.
 - b) If the same alarm is triggered within the set time, the alarm will not be cleared until the suppress alarm time expires. Then the same alarm can be reported again.
4. Select the **Alarm Triggering Mode** to occur once the motion detection alarm has been triggered.
 5. Click **Save**.

Alarm Output 1 – This will cause an alarm output from the camera to a third party device to act on the alarm.

Upload to FTP – The camera will automatically upload snapshots to the specified FTP server when an alarm is triggered.



Note FTP function needs to be configured before the Alarm Upload to FTP setting is selected.

Trigger Storage – The camera will automatically start recording after an alarm is triggered.



Note Post-recording time settings need to be configured before Trigger Storage is selected.

Trigger Email – The camera will automatically send snapshot to the specified email address when an alarm is triggered.



Note Email setup needs to be configured before Trigger Email is selected.

The alarm schedule is used to arm or disarm motion detection alarms. This may be useful to prevent unnecessary alarm triggers during business hours, for example.

The screenshot shows a web interface titled "Enable Schedule". At the top left, there is a checked checkbox labeled "Enable Schedule". Below it are two radio buttons: "Arm" (selected) and "Disarm". To the right is an "Edit" button. The main part of the interface is a grid with 24 columns representing hours (0 to 24) and 7 rows representing days of the week (Mon, Tue, Wed, Thu, Fri, Sat, Sun). The "Arm" state is represented by blue shading. The grid shows that the alarm is armed from 0:00 to 05:30 and from 17:30 to 24:00 on Monday through Friday, and armed 24 hours a day on Saturday and Sunday. At the bottom left of the grid is a "Save" button.

To arm or disarm Motion Detection:

1. Check the **Enable Schedule** checkbox.
2. To make changes to the schedule, click **Edit**.
3. Specify the **Start Time** and **End Time** of the motion detection alarm.
4. If desired, check the **Copy To** checkbox, and the desired days of the week to copy the motion detection alarm schedule to those days.
5. Click **Save**.



Note The Time axis of the Schedule table is based off a 24-hour clock. "0" is 12:00 a.m. (midnight, start of day), "12" is 12:00 p.m. (noon) and "24" is 12:00 a.m. (midnight, end of day).

In the image above, the motion detection alarm is armed from 0:00 (midnight, start of day) to 05:30 (5:30 a.m.) then disarmed for normal business hours, and then armed again from 17:30 (5:30 p.m.) to 24:00 (midnight, end of day) Monday through Friday. On Saturday and Sunday, the motion detection alarm is armed 24 hours a day.

SECURITY SETTINGS

User

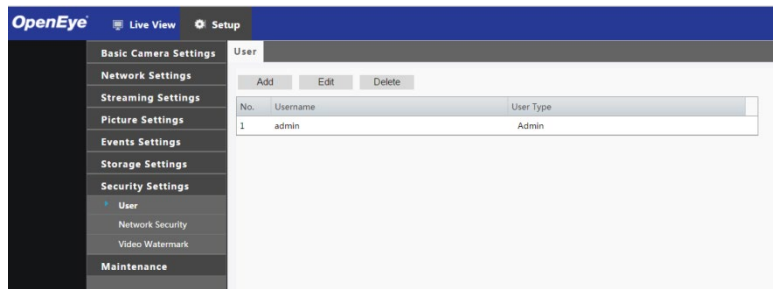

Add User

The user name and passwords are limited to 32 characters with no spaces permitted. There is a maximum of twenty user accounts.

1. Type the new **Username** and **User Type**.
2. Type a **Password**, and then confirm the password.
3. Click **Save**.

Edit User

1. Select the user name on the **User list**.
2. Click **Edit**.
3. In the resulting window, modify the Password and/or feature permissions.
4. Click **Save**.

Delete User

1. Select the user name on the **User list**.
2. Click **Delete** to remove the user.
3. Click **OK** in the confirmation window.

There is a momentary wait time while the Network Camera Manager saves parameters. When this period is complete, the User will be deleted.

Network Security

You can use the Network Security tab to set a secure channel for data transmission.

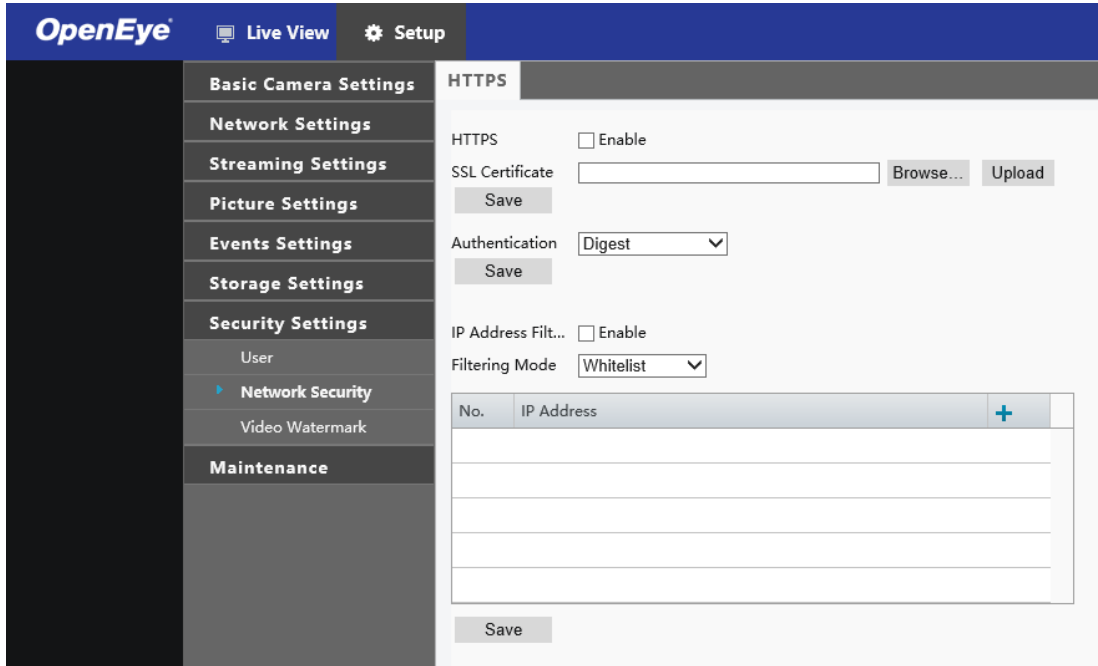

To configure Network Security:

1. Click **Network Settings**, and then click **Port**, and then enter the port number in the **HTTPS Port** box.
2. Click **Save**.
3. Click **Security Settings**, and then click **Network Security**.
4. Check the **Enable HTTPS** checkbox, or click **Browse** to upload your custom **SSL certificate** if desired.
5. Click **Save**.

Real Time Streaming Protocol (RTSP) is an application layer protocol. To transmit and control the audio and video, set RTSP authentication in the web browser. Use the **Authentication** dropdown menu to select the appropriate mode, and then click **Save**.

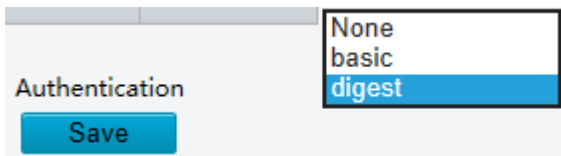

IP Address filtering allows you to configure access from specified IP addresses to your camera.

The screenshot shows a configuration window titled "HTTPS". It contains several sections: "HTTPS" with an "Enable" checkbox; "SSL Certificate" with a text input, "Browse..." button, and "Upload" button; "Authentication" with a dropdown menu set to "Digest" and a "Save" button; "IP Address Filtr..." with an "Enable" checkbox; and "Filtering Mode" with a dropdown menu showing "Whitelist" and "Deny Access". Below the dropdown is a table with columns "No." and "IP Address", a "+" button, and a "Save" button at the bottom.

| No. | IP Address |
|-----|------------|
| | |
| | |
| | |
| | |
| | |

1. Check the **Enable IP Address Filtering** checkbox.
2. Select a **Filtering Mode**, and then click the **+** symbol to add the desired IP addresses to the list.



Note If the Filtering Mode is set to **Whitelist**, only the specified IP addresses are allowed to access the camera. If the Filtering Mode is set to **Deny Access**, the specified IP addresses are denied access. Up to 32 IP addresses can be added to the list.

Video Watermark

Use the Video Watermark to encrypt the camera image and protect the video from being deleted or modified.

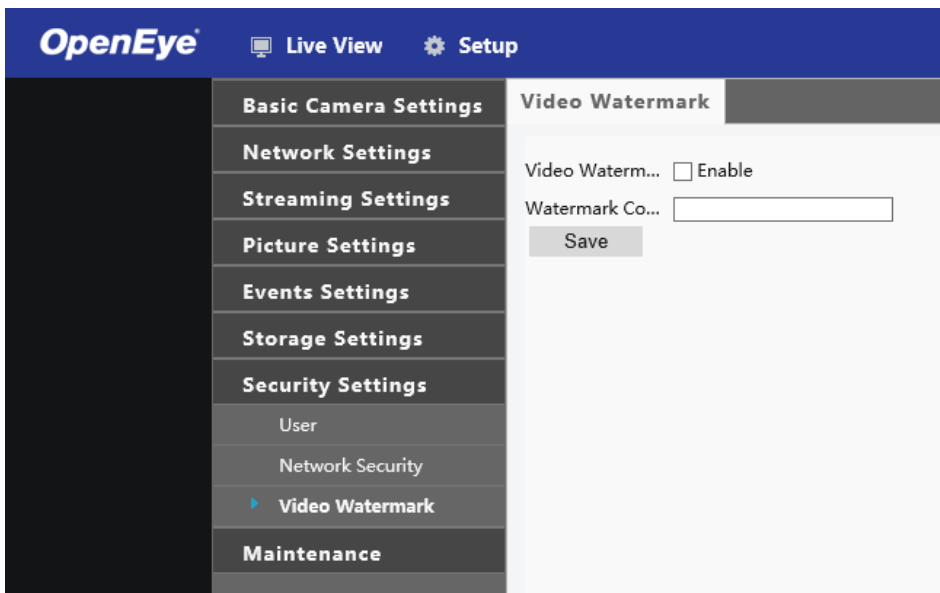

To add a video

watermark:

1. Check the Video Watermark **Enable** checkbox.
2. Type the desired **Watermark Content**.
3. Click **Save**.

MAINTENANCE

Time

The screenshot shows the OpenEye camera maintenance interface. The top navigation bar includes 'OpenEye', 'Live View', and 'Setup'. A sidebar on the left lists various settings categories: Basic Camera Settings, Network Settings, Streaming Settings, Picture Settings, Events Settings, Storage Settings, Security Settings, Maintenance, Time, and Maintenance. The 'Time' section is currently selected. The main content area is divided into two sections: 'NTP Server' and 'DST'. The 'NTP Server' section includes a 'Sync Mode' dropdown set to 'Sync with NTP Server', a 'Time Zone' dropdown set to '(UTC-08:00) Pacific Time(US & Canada)', a 'Device Time' field showing '2017-04-14 13:08:58' and a 'Sync with Computer Time' button, a 'Server Address' field with '2.cctv.pool.ntp.org', and an 'Update interval' field with '600'. A 'Save' button is located below this section. The 'DST' section includes an 'Enable DST' checkbox, a 'Start Time' field with dropdowns for 'Apr', 'First', 'Sun', and '02' h, an 'End Time' field with dropdowns for 'Oct', 'Last', 'Sun', and '02' h, and a 'DST Bias' dropdown set to '60mins'. A 'Save' button is located below this section.

By default, the time setting Sync Mode will be set to Sync with NTP Server.

To configure the time settings:

1. Use the **Time Zone** dropdown to select the appropriate time zone.
2. The **Device Time** will sync with the selected Time Zone, or you can click **Sync with Computer Time**.
3. If desired, type a **Server Address** for the NTP Server.
4. Click **Save**.

To configure Daylight Savings Time (DST):

1. Check the **Enable DST** checkbox.
2. Select a **Start Time** and **End Time**, and then select the **DST Bias**.
3. Click **Save**.

Maintenance

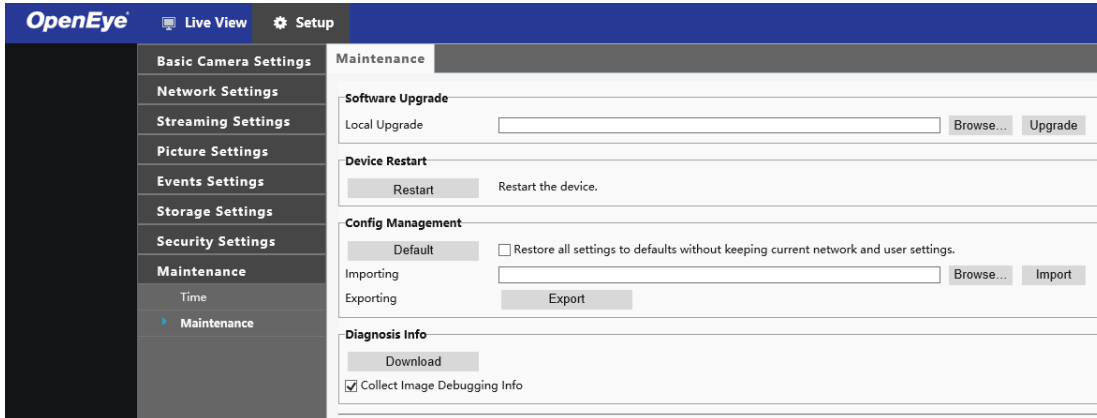

Software Upgrade

To update your camera software:

1. Click **Browse**, select the software file, click **Open**, and then click **Upgrade**.



Note The software file must be a .zip file.

Device Restart

This will restart your camera. A restart may be necessary for some camera settings to take effect.

Configuration Management

You can restore your camera to default settings (without losing your network and user settings) in the Configuration Management tab.

To make this process more efficient in the future, you can Export the current camera configuration file, and then Import the file after the camera has been restored to defaults.

Diagnosis Information

Diagnostic Information includes logs and system configuration. You can export diagnostic information to your PC.



Note Diagnostic information is exported to the local folder as a compressed file. You will need to decompress the file, and then open the file using a text editor.

Check the **Collect Image Debugging Information** checkbox to display the recording and debugging information for convenient troubleshooting.

LOGOUT

The Logout tab allows you to switch between users or cameras.

1. Click **Logout**.
2. If prompted to close the browser window, click **OK**.
3. Using the Network Camera Manager Software, select the camera you wish to view in the Viewer Software.
4. Click **Browse**.
5. Login as the appropriate user.

www.openeye.net
1-888-542-1103

© 2021 OpenEye

All rights reserved. No part of this publication may be reproduced by any means without written permission from OpenEye. The information in this publication is believed to be accurate in all respects. However, OpenEye cannot assume responsibility for any consequences resulting from the use thereof. The information contained herein is subject to change without notice. Revisions or new editions to this publication may be issued to incorporate such changes.